

# HIKOKI

---

## CF 18DSL • CF 18DSAL

---

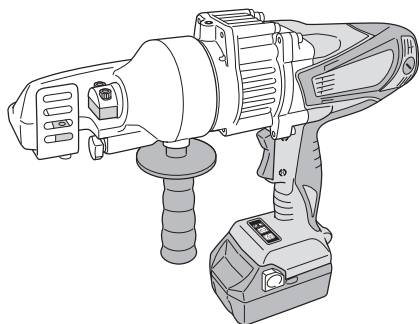

CF18DSL

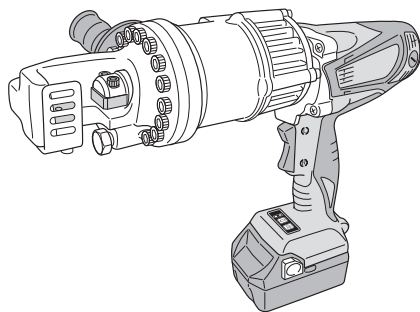

CF18DSAL



Handling instructions

## GENERAL POWER TOOL SAFETY WARNINGS

### WARNING

**Read all safety warnings and all instructions.**

*Failure to follow the warnings and instructions may result in electric shock, fire and/or serious injury.*

**Save all warnings and instructions for future reference.**

*The term "power tool" in the warnings refers to your mains-operated (corded) power tool or battery-operated (cordless) power tool.*

#### 1) Work area safety

- a) **Keep work area clean and well lit.**  
*Cluttered or dark areas invite accidents.*
- b) **Do not operate power tools in explosive atmospheres, such as in the presence of flammable liquids, gases or dust.**  
*Power tools create sparks which may ignite the dust or fumes.*
- c) **Keep children and bystanders away while operating a power tool.**  
*Distractions can cause you to lose control.*

#### 2) Electrical safety

- a) **Power tool plugs must match the outlet. Never modify the plug in any way. Do not use any adapter plugs with earthed (grounded) power tools.**  
*Unmodified plugs and matching outlets will reduce risk of electric shock.*
- b) **Avoid body contact with earthed or grounded surfaces, such as pipes, radiators, ranges and refrigerators.**  
*There is an increased risk of electric shock if your body is earthed or grounded.*
- c) **Do not expose power tools to rain or wet conditions.**  
*Water entering a power tool will increase the risk of electric shock.*
- d) **Do not abuse the cord. Never use the cord for carrying, pulling or unplugging the power tool. Keep cord away from heat, oil, sharp edges or moving parts.**  
*Damaged or entangled cords increase the risk of electric shock.*
- e) **When operating a power tool outdoors, use an extension cord suitable for outdoor use.**  
*Use of a cord suitable for outdoor use reduces the risk of electric shock.*
- f) **If operating a power tool in a damp location is unavoidable, use a residual current device (RCD) protected supply.**  
*Use of an RCD reduces the risk of electric shock.*

#### 3) Personal safety

- a) **Stay alert, watch what you are doing and use common sense when operating a power tool. Do not use a power tool while you are tired or under the influence of drugs, alcohol or medication.**  
*A moment of inattention while operating power tools may result in serious personal injury.*
- b) **Use personal protective equipment. Always wear eye protection.**  
*Protective equipment such as dust mask, non-skid safety shoes, hard hat, or hearing protection used for appropriate conditions will reduce personal injuries.*
- c) **Prevent unintentional starting. Ensure the switch is in the off position before connecting to**

**power source and/or battery pack, picking up or carrying the tool.**

*Carrying power tools with your finger on the switch or energising power tools that have the switch on invites accidents.*

- d) **Remove any adjusting key or wrench before turning the power tool on.**  
*A wrench or a key left attached to a rotating part of the power tool may result in personal injury.*
  - e) **Do not overreach. Keep proper footing and balance at all times.**  
*This enables better control of the power tool in unexpected situations.*
  - f) **Dress properly. Do not wear loose clothing or jewellery. Keep your hair, clothing and gloves away from moving parts.**  
*Loose clothes, jewellery or long hair can be caught in moving parts.*
  - g) **If devices are provided for the connection of dust extraction and collection facilities, ensure these are connected and properly used.**  
*Use of dust collection can reduce dust-related hazards.*
- #### 4) Power tool use and care
- a) **Do not force the power tool. Use the correct power tool for your application.**  
*The correct power tool will do the job better and safer at the rate for which it was designed.*
  - b) **Do not use the power tool if the switch does not turn it on and off.**  
*Any power tool that cannot be controlled with the switch is dangerous and must be repaired.*
  - c) **Disconnect the plug from the power source and/or the battery pack from the power tool before making any adjustments, changing accessories, or storing power tools.**  
*Such preventive safety measures reduce the risk of starting the power tool accidentally.*
  - d) **Store idle power tools out of the reach of children and do not allow persons unfamiliar with the power tool or these instructions to operate the power tool.**  
*Power tools are dangerous in the hands of untrained users.*
  - e) **Maintain power tools. Check for misalignment or binding of moving parts, breakage of parts and any other condition that may affect the power tool's operation. If damaged, have the power tool repaired before use.**  
*Many accidents are caused by poorly maintained power tools.*
  - f) **Keep cutting tools sharp and clean.**  
*Properly maintained cutting tools with sharp cutting edges are less likely to bind and are easier to control.*
  - g) **Use the power tool, accessories and tool bits etc. in accordance with these instructions, taking into account the working conditions and the work to be performed.**  
*Use of the power tool for operations different from those intended could result in a hazardous situation.*
- #### 5) Battery tool use and care
- a) **Recharge only with the charger specified by the manufacturer.**  
*A charger that is suitable for one type of battery pack may create a risk of fire when used with another battery pack.*
  - b) **Use power tools only with specifically designated battery packs.**  
*Use of any other battery packs may create a risk of injury and fire.*

- c) When battery pack is not in use, keep it away from other metal objects, like paper clips, coins, keys, nails, screws or other small metal objects, that can make a connection from one terminal to another.

Shorting the battery terminals together may cause burns or a fire.

- d) Under abusive conditions, liquid may be ejected from the battery; avoid contact. If contact accidentally occurs, flush with water. If liquid contacts eyes, additionally seek medical help.

Liquid ejected from the battery may cause irritation or burns.

6) Service

- a) Have your power tool serviced by a qualified repair person using only identical replacement parts.

This will ensure that the safety of the power tool is maintained.

**PRECAUTION**

Keep children and infirm persons away.

When not in use, tools should be stored out of reach of children and infirm persons.

**CORDLESS STEEL REBAR CUTTER SAFETY WARNINGS**

**WARNING**

- Do not undertake tasks that go beyond the cutting capabilities of this tool as listed in the specifications column. Also, do not cut hard materials whose tensile strength exceeds 490 N/mm<sup>2</sup>. Doing so could result in injury from flying fragments.

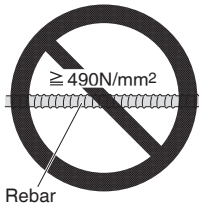

- Make sure to use the product with the anti-scattering guard attached at all times. Never use the tool with the guard removed.

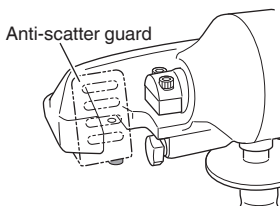

- Always wear a helmet, safety boots and other protective equipment when working.

- Hydraulic oil is flammable and the following precautions should be taken to avoid fire.

- Do not remove the pump cases oil plug during operation or when the tool is warm.
- Replenish hydraulic oil after the tool has sufficiently cooled.
- When replenishing hydraulic oil, choose a location where there are no combustibles in the vicinity and avoid any spilling. Should the oil be spilled, make sure to thoroughly wipe it up.

- Do not smoke when replenishing hydraulic oil or while operating the tool.

- Do not operate the tool near the location where hydraulic oil was replenished.

- When cutting rebar, make sure that the rebar is deeply sandwiched between the cutting block. If not placed deep enough, the cutter block may be damaged or fragments may fly, resulting in accident or injury.

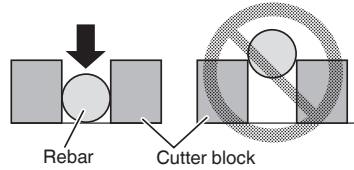

- Never set the rebar in a slant where it sticks out above the anti-scatter guard.

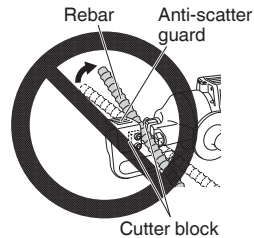

- When operating the switch, never place your fingers near the cutter block. Doing so can result in injury.

- Do not cut rebar down to a length that is any shorter than 30 cm. Also, do not cut 2 or more rebars at one time. Doing so can result in flying fragments that may result in accident or injury.

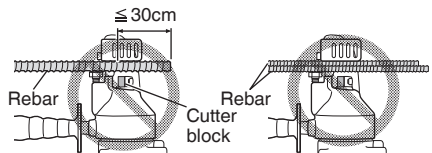

- Do not use a damaged cutter block. Replace it with a new one as a damaged cutter block will not only cause damage to the tool, but accidents as well. If deformed, the cutter block can be used by changing the direction in which it is attached.

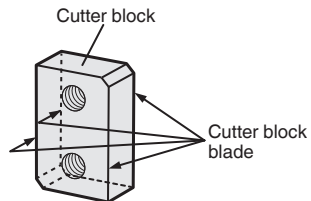

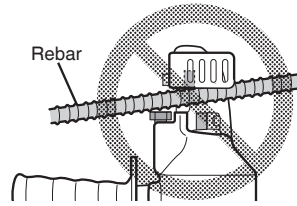
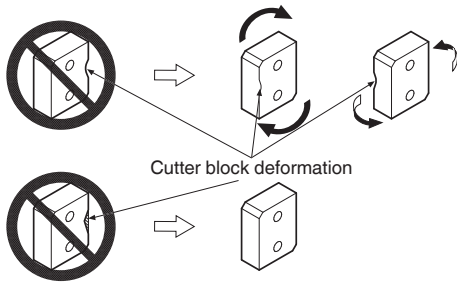

10. Prior to use, conduct a trial run. If during the trial run or while using the tool, there are any indications of trouble, abnormal sounds or abnormal vibrations, immediately switch off the tool, discontinue use and arrange for inspection or repairs with a HiKOKI Authorized Service Center. Continued use may result in injury.
11. If you accidentally drop or bump the tool, check it for damage, cracks or deformities. If there are any, they may result in injury.

### CAUTION

1. Before operation, inspect the cutter block and housing for loose bolts, hydraulic oil volume etc. Also, make sure to remove any attached tools such as a wrench.
2. Make sure to remove the battery when inspecting, cleaning or exchanging the cutter block. Accidentally switching the tool on may result in injury.
3. Make sure there is nobody below when working in high locations. Dropping the tool or other materials could result in accident or injury.
4. Only use genuine hydraulic oil. The genuine oil must be the equivalent of international ISO auxiliary viscosity grade 46 (VG46).
5. If hydraulic oil comes into contact with eyes, do not rub. Wash immediately and thoroughly with clean running water and contact a physician for treatment. Left untreated, the oil may lead to eye damage.
6. If hydraulic oil comes into contact with skin, wash immediately and thoroughly with clean water and soap. Failure to do so may lead to skin inflammation.
7. If hydraulic oil is accidentally swallowed, do not attempt to vomit. Immediately contact a physician for treatment.
8. When hydraulic oil is not in use, make sure the lid of the container is secure and store it in a dark place away from direct sunlight and out of the reach of children.
9. Do not place the hydraulic oil container near a combustion source such as heat, flame or sparks. Doing so may result in explosion.
10. Make sure the battery is securely attached. If not securely attached, the battery could come loose and cause injury.
11. Do not throw away battery with regular trash or dispose in fire.
12. Store the battery in a location out of the reach of children.
13. Use the battery correctly in accordance with its specifications.

- Keep the switch on until the piston reaches the tip.
  - When switched on, the piston will not move forward until it has completely returned. This is to ensure that the next oil pressure is not applied while the hydraulic valve inside the tool remains open.
4. Replace the blade at an early stage. Using a chipped or deformed blade could result in injury from flying fragments.
  5. Use the provided hex. bar wrench (4 mm) when installing or removing the cutter block. Using a tool other than the one provided may result in too much or not enough tightening that can lead to injury.
  6. When replenishing hydraulic oil:
    - Always make sure it is done when the temperature of both the tool and the hydraulic oil is cool. Removing the oil plug while the tool is hot can result in the oil inside the tool to spray out and cause accident or injury.
    - Try to avoid inserting air when injecting the oil.

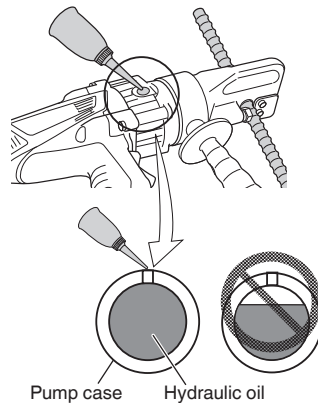

### CAUTION ON LITHIUM-ION BATTERY

To extend the lifetime, the lithium-ion battery equips with the protection function to stop the output. In the cases of 1 to 3 described below, when using this product, even if you are pulling the switch, the motor may stop. This is not the trouble but the result of protection function.

1. When the battery power remaining runs out, the motor stops. In such a case, charge it up immediately.
  2. If the tool is overloaded, the motor may stop. In this case, release the switch of tool and eliminate causes of overloading. After that, you can use it again.
  3. If the battery is overheated under overload work, the battery power may stop. In this case, stop using the battery and let the battery cool. After that, you can use it again.
- Furthermore, please heed the following warning and caution.

### ADDITIONAL SAFETY WARNINGS

1. If the switch does not return to its original position, immediately discontinue use and arrange for repairs with the HiKOKI Authorized Service Center.
2. Do not strike or apply strong impact to the switch panel. Doing so can lead to damage.
3. While operating the tool:
  - Make sure the rebar does not slant diagonally.

## WARNING

In order to prevent any battery leakage, heat generation, smoke emission, explosion and ignition beforehand, please be sure to heed the following precautions.

1. Make sure that swarf and dust do not collect on the battery.
- During work make sure that swarf and dust do not fall on the battery.
- Make sure that any swarf and dust falling on the power tool during work do not collect on the battery.
- Do not store an unused battery in a location exposed to swarf and dust.
- Before storing a battery, remove any swarf and dust that may adhere to it and do not store it together with metal parts (screws, nails, etc.).
2. Do not pierce battery with a sharp object such as a nail, strike with a hammer, step on, throw or subject the battery to severe physical shock.
3. Do not use an apparently damaged or deformed battery.
4. Do not use the battery in reverse polarity.
5. Do not connect directly to an electrical outlets or car cigarette lighter sockets.
6. Do not use the battery for a purpose other than those specified.
7. If the battery charging fails to complete even when a specified recharging time has elapsed, immediately stop further recharging.
8. Do not put or subject the battery to high temperatures or high pressure such as into a microwave oven, dryer, or high pressure container.
9. Keep away from fire immediately when leakage or foul odor are detected.
10. Do not use in a location where strong static electricity generates.
11. If there is battery leakage, foul odor, heat generated, discolored or deformed, or in any way appears abnormal during use, recharging or storage, immediately remove it from the equipment or battery charger, and stop use.

## CAUTION

1. If liquid leaking from the battery gets into your eyes, do not rub your eyes and wash them well with fresh clean water such as tap water and contact a doctor immediately.  
If left untreated, the liquid may cause eye-problems.
2. If liquid leaks onto your skin or clothes, wash well with clean water such as tap water immediately.  
There is a possibility that this can cause skin irritation.
3. If you find rust, foul odor, overheating, discolor, deformation, and/or other irregularities when using the battery for the first time, do not use and return it to your supplier or vendor.

## WARNING

If a conductive foreign matter enters in the terminal of lithium ion battery, the battery may be shorted, causing fire. When storing the lithium ion battery, obey surely the rules of following contents.

- Do not place conductive debris, nail and wires such as iron wire and copper wire in the storage case.
- To prevent shorting from occurring, load the battery in the tool or insert securely the battery cover for storing until the ventilator is not seen.

## REGARDING LITHIUM-ION BATTERY TRANSPORTATION

When transporting a lithium-ion battery, please observe the following precautions.

## WARNING

Notify the transporting company that a package contains a lithium-ion battery, inform the company of its power output and follow the instructions of the transportation company when arranging transport.

- Lithium-ion batteries that exceed a power output of 100Wh is considered Dangerous Goods and will require special application procedures.
- For transportation abroad, you must comply with international law and the rules and regulations of the destination country.

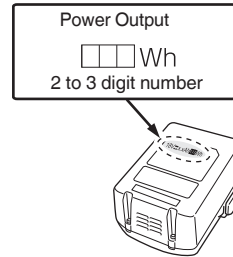





















## NAMES OF PARTS (Fig. 1 – Fig. 11)

①	Anti-scatter guard
②	Housing
③	Piston
④	Release valve
⑤	Pump case
⑥	Brush cap
⑦	Cutter block
⑧	Side handle
⑨	Motor
⑩	Nameplate
⑪	Oil plug
⑫	Adjustment bolt
⑬	Switch
⑭	Battery
⑮	Switch panel
⑯	Remaining battery indicator switch
⑰	Remaining battery indicator lamp
⑱	Light switch: Cannot be used with this tool.
⑲	Rebar
⑳	Cutter block blade
㉑	Cutter block deformation
㉒	Cutter block fragment
㉓	Open ended wrench
㉔	Hydraulic oil
㉕	Hex. bar wrench (5mm)
㉖	Hex. bar wrench (4mm)
㉗	Hex. Socket bolt
㉘	Latch

## SYMBOLS

### WARNING

The following show symbols used for the machine. Be sure that you understand their meaning before use.

	CF18DSL / CF18DSAL : Cordless Steel Rebar Cutter
	Read all safety warnings and all instructions.
	Always wear eye protection.
	Wear head protection
	No open flame; Fire, open ignition source and smoking prohibited
	Keep your hands away
	Keep your face away
	Direct current
	Rated voltage
	The maximum diameter that can be cut
	Disconnect the battery
	Light switch: Cannot be used with this tool
	Switching ON
	Operates the same on either side
	Remaining battery indicator switch
	The battery remaining power is nearly empty. Recharge the battery soonest possible
	The battery remaining power is a half.
	The battery remaining power is enough.
	Bites into rebar
	Prohibited action
	Warning

## STANDARD ACCESSORIES

In addition to the main unit (1 unit), the package contains the accessories listed on page 8.

Standard accessories are subject to change without notice.

## APPLICATIONS

Cutting rebar to be used for reinforcing concrete

## SPECIFICATIONS

Model	CF18DSL	CF18DSAL
Voltage	18 V	
Cutting capacity	Up to 16 mm diameter	Up to 20 mm diameter
Cutting speed	4 sec.	6.5 sec.
Max. Rebar hardness	Tensile strength 490 N/mm <sup>2</sup>	
Head angle of rotation	345°	360°
Dimensions (LxWxH)	370 x 90 x 306 mm (without side handle)	413 x 103 x 316 mm (without side handle)
Weight	6.6 kg (BSL1850)	9.4 kg (BSL1850)

### NOTE

Due to HiKOKI's continuing program of research and development, the specifications herein are subject to change without prior notice.

## CHARGING

For rechargeable batteries, please charge in according to the handling instruction of the charger which you are using. (Fig.3)

## REGARDING ENVIRONMENT AND CONDITIONS OF USE

This tool operates on oil pressure. When used during the winter season or in cold conditions the hydraulic oil's viscosity will excessively rise to dull the tool's operation. In such cases, run the tool through a warm-up operation prior to use.

How to run a warm-up operation  
Without setting up a rebar, switch on the tool and let it continuously run for 30 to 60 seconds.

### WARNING

Do not place your hands in the vicinity of the piston during warm-up operation.

Depending on the environment and conditions of use, the hydraulics may heat up (over 50°C). This can lower the viscosity of the hydraulic oil and reduce its cutting power. If this occurs, allow the tool to cool down and then resume operation.

## MOUNTING AND OPERATION

Action	Figure	Page
Removing and inserting the battery	2	9
Charging	3	9
Switch operation	4	10
Regarding the switch panel (Remaining battery indicator)	5	10
Regarding the rotation mechanism of the tool head	6	10
Cutting	7	11
If the tool bites into a rebar	8	12
Changing the cutter block*	9	12

How to replenish the hydraulic oil	10	13
Check and replacing the carbon brush	11	14
Selecting accessories	—	15

\* Changing the cutter block

With repeated rebar cutting, the cutter block will sustain damage such as blade wear, deformation or chipping. When a worn, deformed or chipped cutter block is used, the piston may not return due to the rebar not being fully cut and remaining sandwiched by the cutter block. Furthermore, this could lead to tool malfunction or damage to the cutter block.

- 1000 cuts per single blade location  
The life (number of cuts) of a single location on the blade is approximately 1000.
- 4 blade locations on a single cutter block  
There are 4 blade locations on the cutter block which can be used by re-attaching and changing the facing of the block 4 times.
- Change the cutter block as early as possible  
Change the facing of the cutter block or exchange it if the blade is chipped or deformed.



## MAINTENANCE AND INSPECTION

### 1. Maintenance after use

After using the tool, put on a pair of leather gloves and clean off the metal particles and other waste matter around the piston.

#### NOTE

Metal particle buildup can cause the piston to seize up.

#### WARNING

Do not blow away the waste matter with an airgun or similar tool.  
Sharp-edged fragments can cause injury when scattered in the air.

### 2. Check the cutter block

Periodically check the blade for chipping or deformation.

#### WARNING

Replace the blade at an early stage. Using a chipped or deformed blade could result in injury from flying fragments.

### 3. Check hydraulic oil volume

Over 70% of reduced cutting power is the result of insufficient hydraulic oil volume. Before using the tool, always check the hydraulic oil volume.

### 4. Inspecting the mounting screws

Regularly inspect all mounting screws and ensure that they are properly tightened. Should any of the screws be loose, retighten them immediately. Failure to do so could result in serious hazard.

### 5. Maintenance of the motor

The motor unit winding is the very "heart" of the power tool. Exercise due care to ensure the winding does not become damaged and/or wet with oil or water.

### 6. Inspecting the carbon brushes (Fig. 11)

The motor employs carbon brushes which are consumable parts. Since and excessively worn carbon brush with new ones when it becomes worn to or near the "wear limit" (⊙). In addition, always keep carbon brushes clean and ensure that they slide freely within the brush holders.

#### NOTE

When replacing the carbon brush with a new one, be sure to use the HiKOKI Carbon Brush Code No. 999100.

### 7. Replacing carbon brushes (Fig. 11)

Take out the carbon brush by first removing the brush cap and then hooking the protrusion of the carbon brush with a flat head screw driver, etc.

When installing the carbon brush, choose the direction so that the nail (⊙) of the carbon brush agrees with the contact portion (⊙) outside the brush tube. Then push it in with a finger. Lastly, install the brush cap.

#### CAUTION

Be absolutely sure to insert the nail of the carbon brush into the contact portion outside the brush tube. (You can insert whichever one of the two nails provided).

Caution must be exercised since any error in this operation can result in the deformed nail of the carbon brush and may cause motor trouble at an early stage.

### 8. Cleaning on the outside

When the power tool is stained, wipe with a soft dry cloth or a cloth moistened with soapy water. Do not use chloric solvents, gasoline or paint thinner, for they melt plastics.

### 9. Storage

Storing in a place below 40°C and out of the reach of children.

#### NOTE

Storing lithium-ion batteries.

Make sure the lithium-ion batteries have been fully charged before storing them.

Prolonged storage (3 months or more) of batteries with a low charge may result in performance deterioration, significantly reducing battery usage time or rendering the batteries incapable of holding a charge.

However, significantly reduced battery usage time may be recovered by repeatedly charging and using the batteries two to five times.

If the battery usage time is extremely short despite repeated charging and use, consider the batteries dead and purchase new batteries.

#### CAUTION







In the operation and maintenance of power tools, the safety regulations and standards prescribed in each country must be observed.

#### Important notice on the batteries for the HiKOKI cordless power tools

Please always use one of our designated genuine batteries. We cannot guarantee the safety and performance of our cordless power tool when used with batteries other than those designated by us, or when the battery is disassembled and modified (such as disassembly and replacement of cells or other internal parts).

#### NOTE

Due to HiKOKI's continuing program of research and development, the specifications herein are subject to change without prior notice.

		 4 mm	 5 mm			
CF18DSL (NK)	1	1	-	1	1	1
CF18DSAL (NK)	-	1	1	1	1	1



1

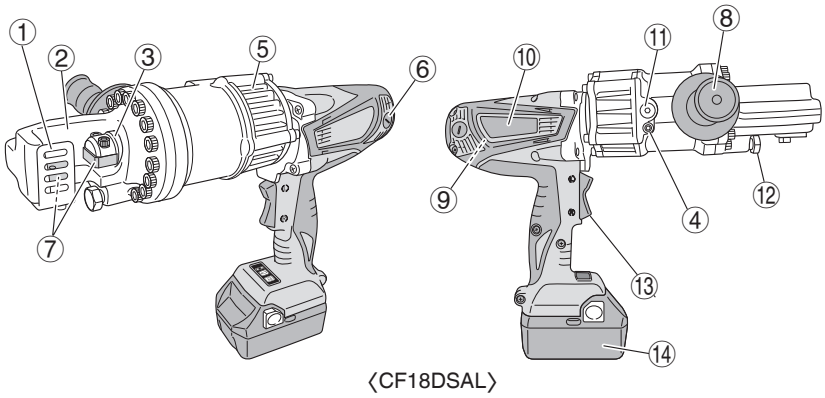
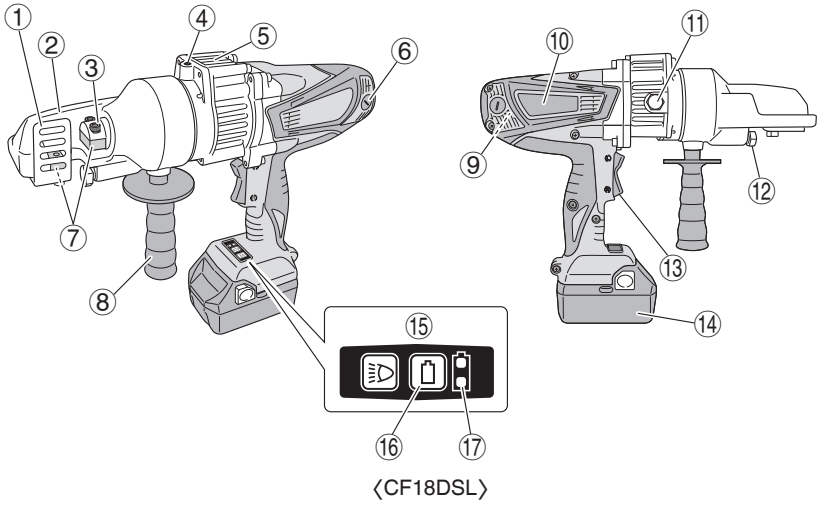

2

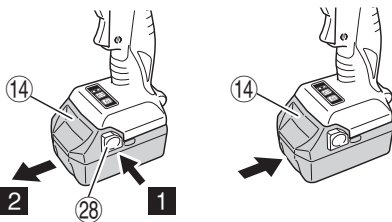

3

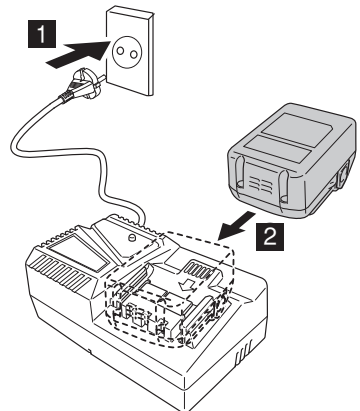

4

I

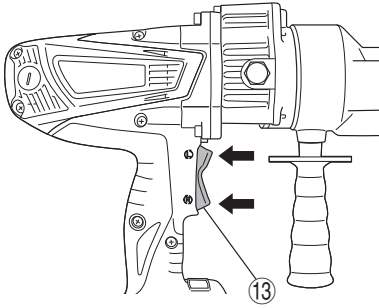

O

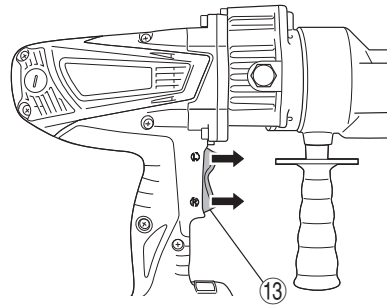

5

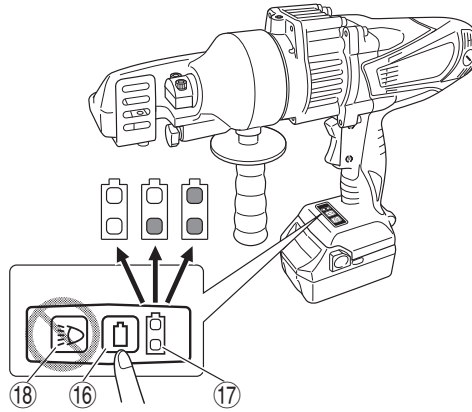

6

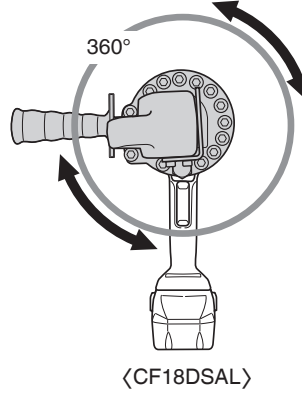
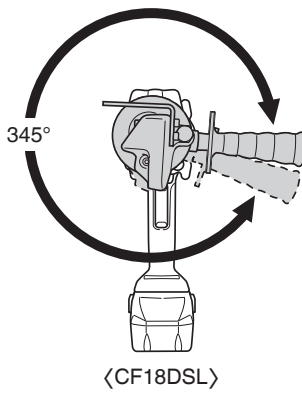

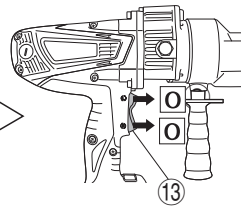
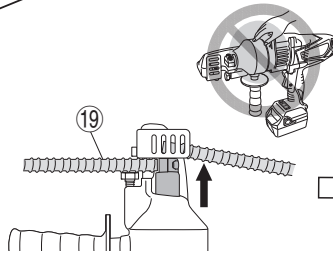
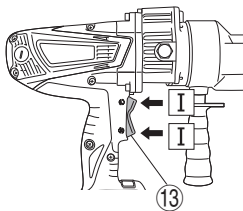
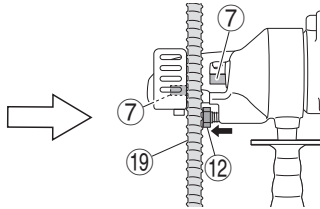
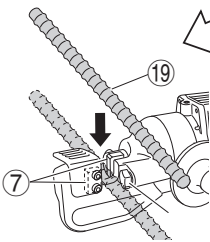
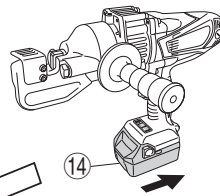
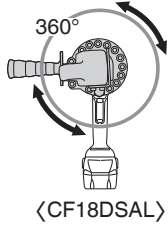
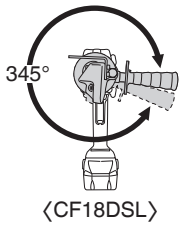
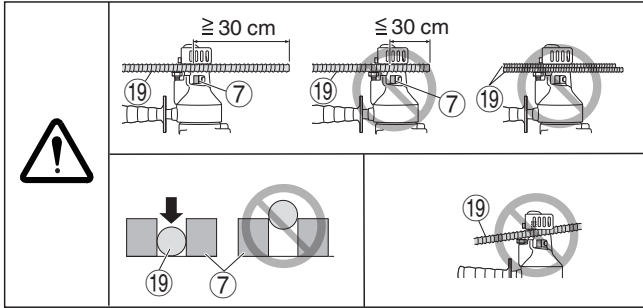

8

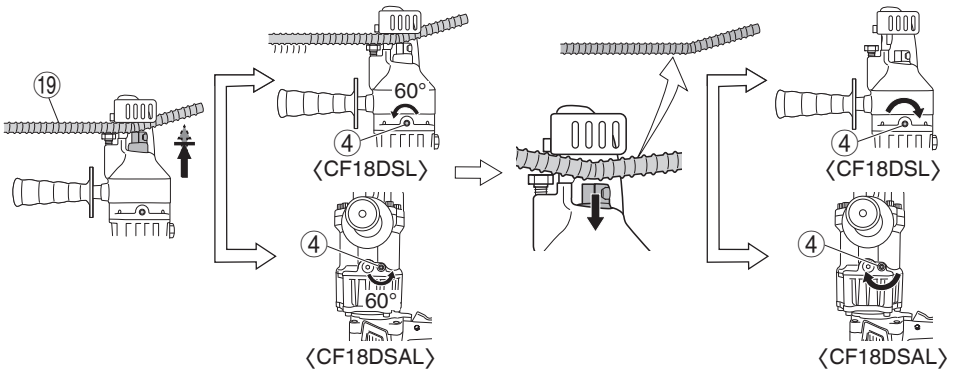

9

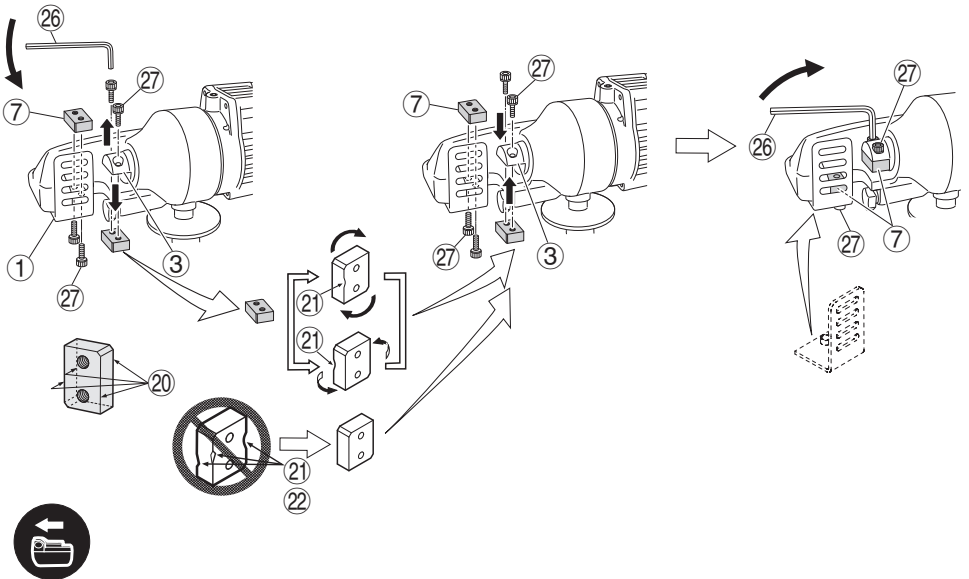

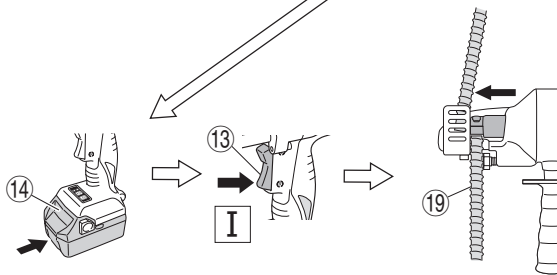
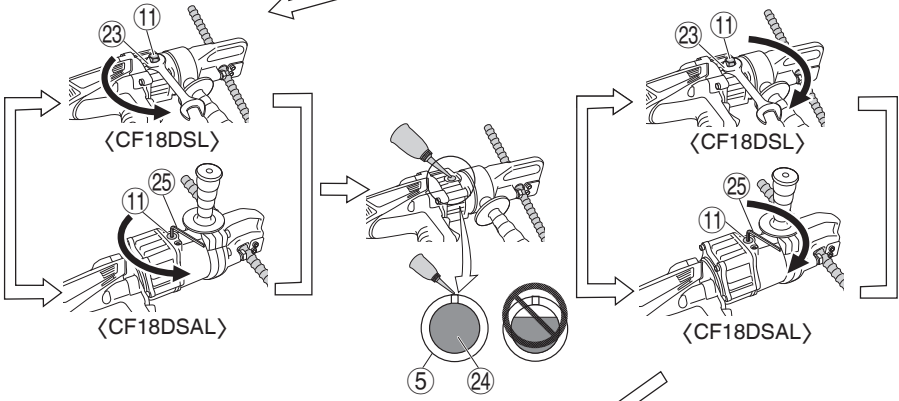
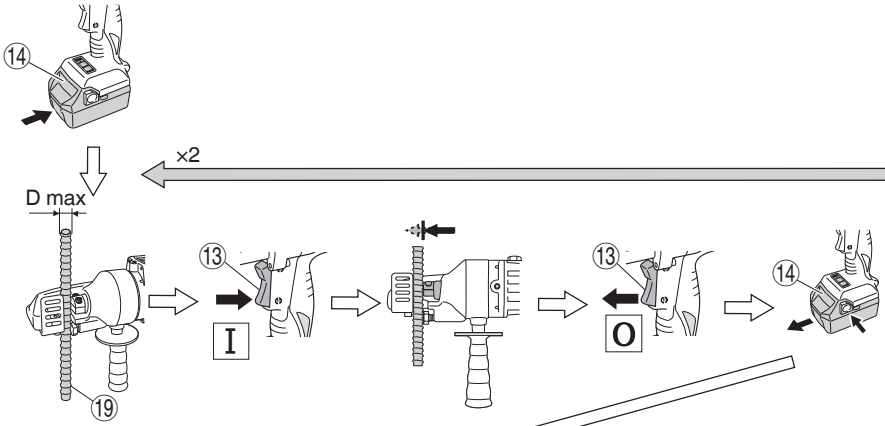

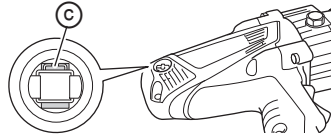
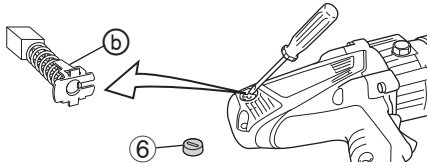
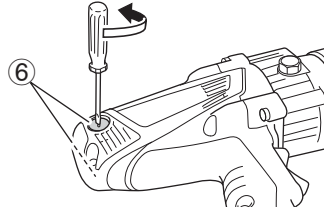
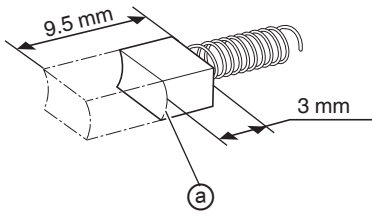



18V (Li-ion)

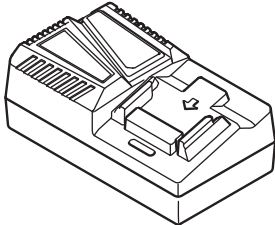
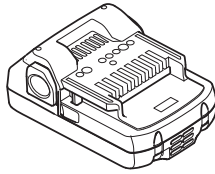

UC18YFSL (14.4V – 18V)

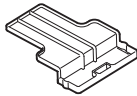

329897



944458

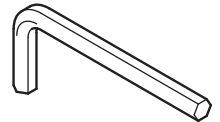

944459

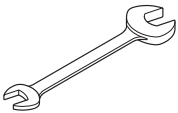

931161

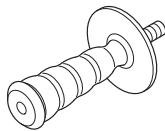

306254



306295

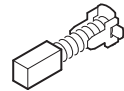

999100

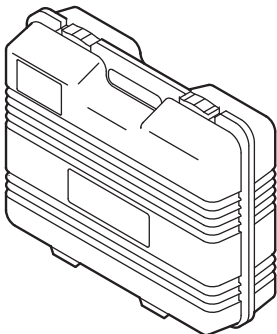

338710

# Koki Holdings Co., Ltd.

Shinagawa Intercity Tower A, 15-1, Konan 2-chome,  
Minato-ku, Tokyo, Japan